

REVISIONS		
REV. NO.	DESCRIPTION	DATE

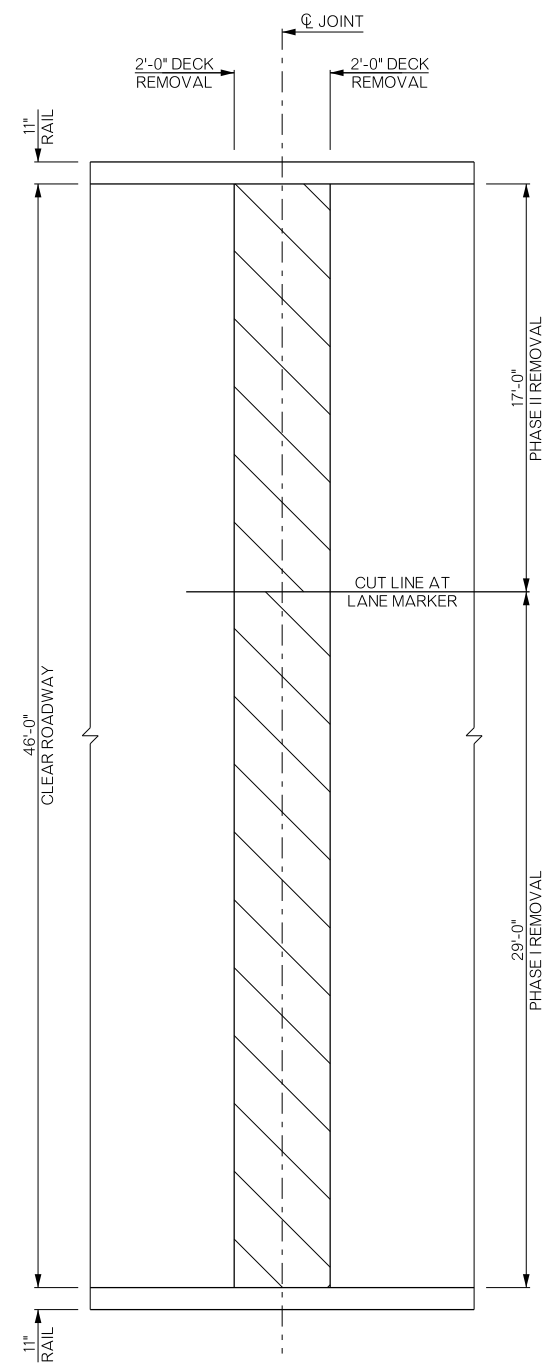

DETAIL OF DECK REMOVAL AT CONSTRUCTION JOINT

THE CONTRACTOR SHALL AVOID CUTTING INTO STRUCTURAL STEEL BENEATH BRIDGE DECK DURING SAWING.

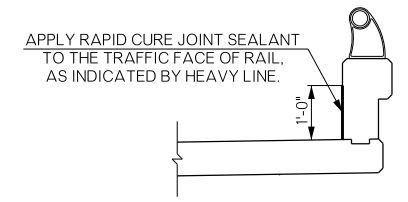

REHABILITATED CONSTRUCTION JOINT AT TRAFFIC RAIL

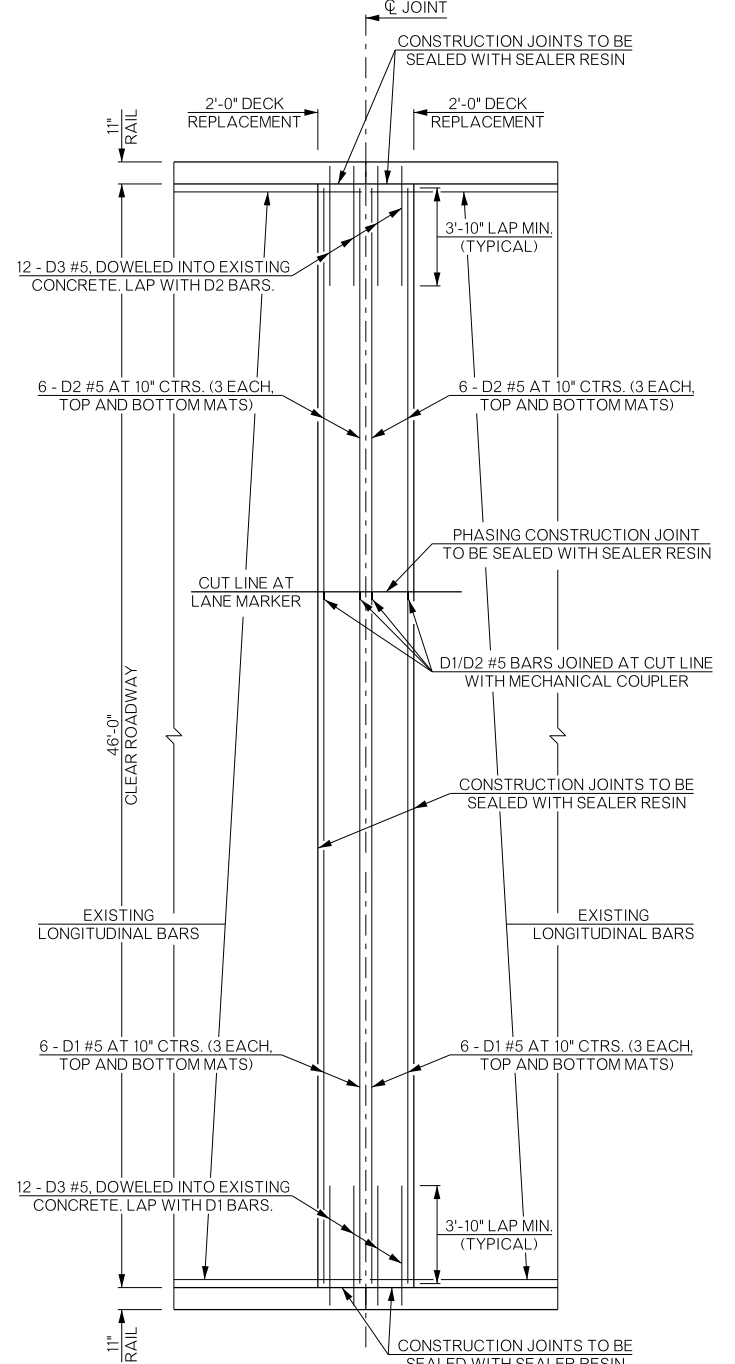

DETAIL OF DECK REPAIR AT CONSTRUCTION JOINT

NOTE: D4 AND D5 BARS NOT SHOWN FOR CLARITY.

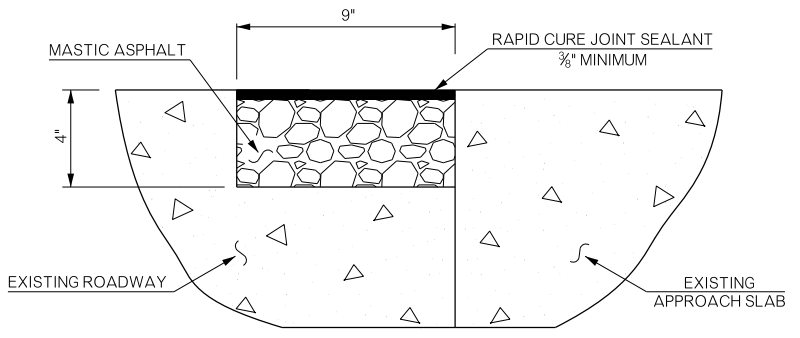

REHABILITATED RELIEF JOINTS AT APPROACH SLABS

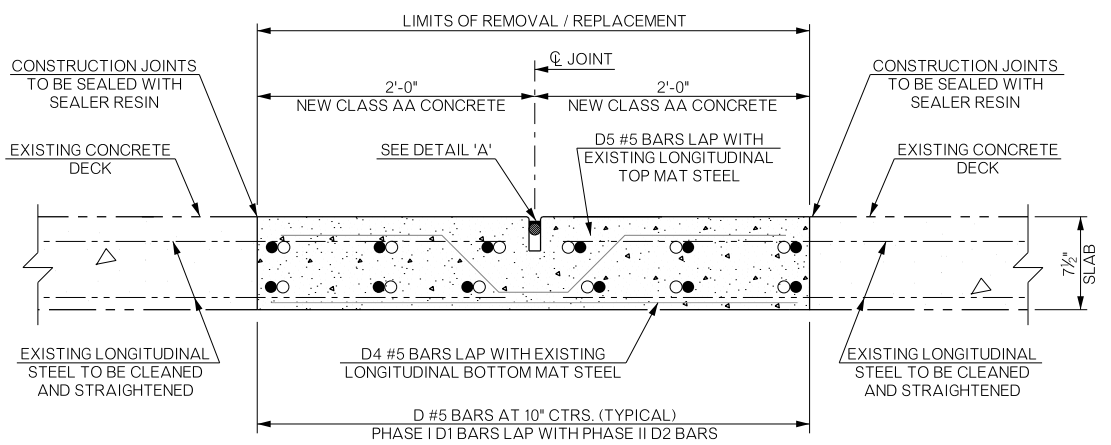

TYPICAL SECTION OF REHABILITATED CONSTRUCTION JOINT

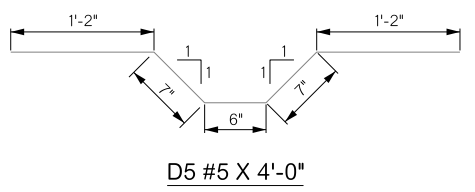

D5 #5 X 4'-0"

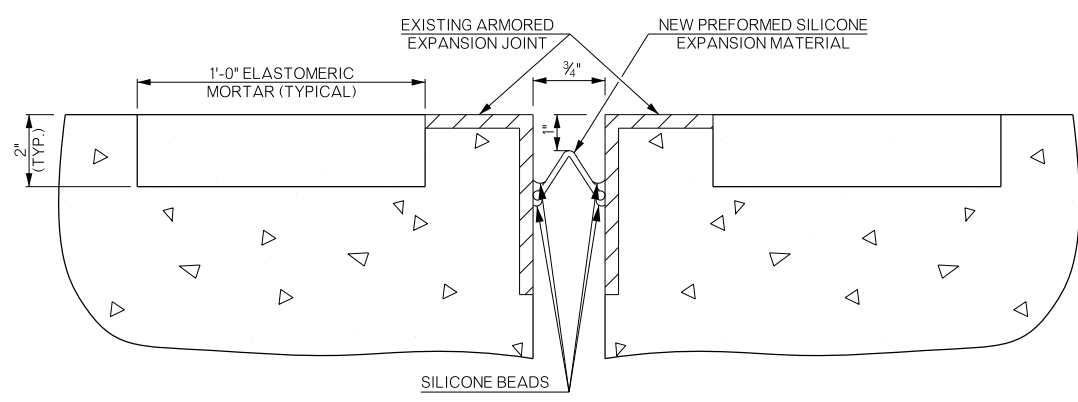

REHABILITATED EXPANSION JOINT AT ABUTMENT NO. 1

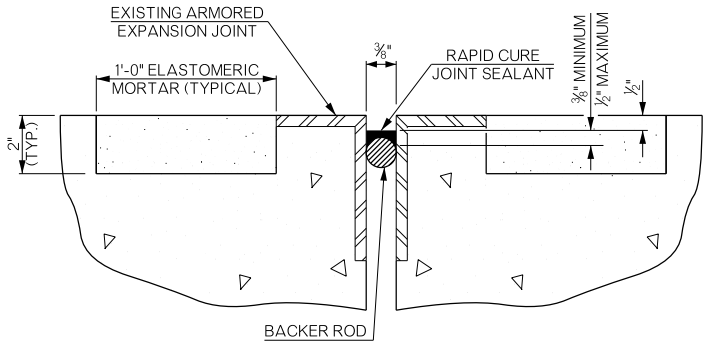

REHABILITATED EXPANSION JOINT AT ABUTMENT NO. 2

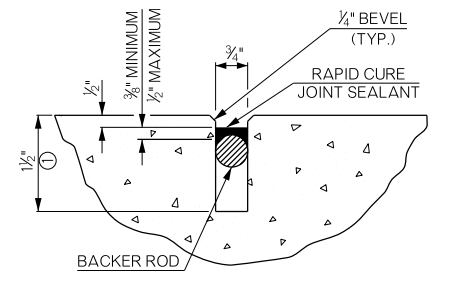

DETAIL 'A'

① SAW TO THE DEPTH SHOWN TO PROVIDE CLEAN, STRAIGHT SURFACES.

BAR LIST ONE JOINT REPAIR (PHASE I) (7 REQUIRED FOR BRIDGE)				
MARK	NO.	SIZE	FORM	LENGTH
EPOXY COATED				
D1	12	#5	STR.	28'-10"
D3	12	#5	STR.	5'-0"
D4	46	#5	STR.	3'-8"
D5	18	#5	BNT.	4'-0"

BAR LIST ONE JOINT REPAIR (PHASE II) (7 REQUIRED FOR BRIDGE)				
MARK	NO.	SIZE	FORM	LENGTH
EPOXY COATED				
D2	12	#5	STR.	16'-10"
D3	12	#5	STR.	5'-0"
D4	28	#5	STR.	3'-8"
D5	11	#5	BNT.	4'-0"

② LENGTH OF ANCHORAGE SYSTEM TO BE DETERMINED BY MANUFACTURERS SPECIFICATIONS (SEE GENERAL NOTES)

QUANTITIES ONE CONSTRUCTION JOINT REPAIR (7 REQUIRED FOR BRIDGE)				
ITEM	UNIT	PHASE I	PHASE II	TOTAL
RAPID CURE JOINT SEALANT	L.F.	30.00	18.00	48.00
CLASS AA CONCRETE	C.Y.	2.70	1.60	4.30
EPOXY COATED REINFORCING STEEL	LB.	680.00	430.00	1,110.00
SEALER CRACK PREPARATION	L.F.	62.00	42.00	104.00
SEALER RESIN	GAL.	0.50	0.30	0.80
(SP) CORROSION INHIBITOR (SURFACE APPLIED)	S.Y.	5.00	3.00	8.00

BRIDGE "B" US-69 NORTHBOUND OVER US-70	BRYAN COUNTY	Design	N/A	N/A
DETAILS OF JOINT REHABILITATION (BRIDGE "B")		Detail	DAN	5/16
		Check	TEE	6/16
		Squad	HENSLEY	
		Engr.	DEFRANCO	